



DANMIL DAVOC CAP

Verification Report

Removal of hydrocarbons from polluted air

| | |
|------------------------|----------------------------|
| Date | 29. June 2010 |
| Project Manager | Marianne Kyed Ørbæk |
| Task no | 110-22627 |



0. Table of contents

| | |
|--|-----------|
| 0. TABLE OF CONTENTS..... | 2 |
| 1. ABBREVIATIONS AND DEFINITIONS..... | 3 |
| 2. INTRODUCTION..... | 4 |
| 2.1. NAME OF PRODUCT | 4 |
| 2.2. NAME AND CONTACT OF VENDOR | 4 |
| 2.3. NAME OF CENTRE / VERIFICATION RESPONSIBLE | 4 |
| 2.4. VERIFICATION DOCUMENTATION..... | 4 |
| 2.4.1. VERIFICATION DOCUMENT STATUS | 5 |
| 2.5. VERIFICATION PROCESS | 5 |
| 2.6. VERIFICATION AND TEST ORGANIZATION | 5 |
| 2.7. EXPERT GROUP | 6 |
| 3. DESCRIPTION OF THE TECHNOLOGY | 6 |
| 4. DESCRIPTION OF THE PRODUCT..... | 7 |
| 5. APPLICATION AND PERFORMANCE PARAMETER DEFINITIONS..... | 8 |
| 5.1. MATRIX | 8 |
| 5.2. TARGET..... | 8 |
| 5.3. EFFECTS | 8 |
| 5.4. PERFORMANCE PARAMETERS FOR VERIFICATION | 8 |
| 5.5. ADDITIONAL PARAMETERS | 8 |
| 6. EXISTING DATA..... | 8 |
| 7. TEST PLAN REQUIREMENTS | 9 |
| 7.1. TEST DESIGN | 9 |
| 7.2. REFERENCE ANALYSIS..... | 9 |
| 7.3. DATA MANAGEMENT | 9 |
| 7.4. QUALITY ASSURANCE | 9 |
| 7.5. TEST REPORT | 9 |
| 8. EVALUATION | 9 |
| 8.1. CALCULATION OF PERFORMANCE PARAMETERS | 10 |
| 8.2. PERFORMANCE PARAMETER SUMMARY..... | 10 |
| 8.2.1. TEST RESULTS | 10 |
| 8.3. EVALUATION OF TEST QUALITY | 11 |
| 8.4. CONTROL OF DATA QUALITY | 11 |
| 8.5. DEVIATIONS..... | 11 |
| 8.6. ADDITIONAL PARAMETER SUMMARY..... | 11 |
| 8.7. PRODUCT COSTS | 11 |
| 8.8. OCCUPATIONAL HEALTH AND ENVIRONMENT | 11 |
| 8.9. RECOMMENDATIONS FOR VERIFICATION STATEMENT | 12 |
| 9. REFERENCES..... | 13 |
| 10. APPENDIX | 13 |



1. Abbreviations and definitions

The abbreviations and definitions used in the test and verification report are summarized below.

| Word | DANETV |
|------------------------|--|
| Effect | The way the target is affected |
| ETV | Environmental technology verification (ETV) is an independent (third party) assessment of the performance of a technology or a product for a specified application, under defined conditions and adequate quality assurance. |
| Evaluation | Evaluation of test data for a technology product for performance and data quality |
| Matrix | The type of material that the product is intended for |
| Method | Generic document that provides rules, guidelines or characteristics for tests or analysis |
| Performance claim | The effects foreseen by the vendor on the target(s) in the matrix of intended use |
| Performance parameters | Parameters that can be documented quantitatively in tests and that provide the relevant information on the performance |
| QA | Quality assurance |
| Standard | Generic document established by consensus and approved by a recognized standardization body that provides rules, guidelines or characteristics for tests or analysis |
| Target | The property that is affected by the product |
| Test/testing | Determination of the performance of a product for parameters defined for the application |
| Verification | Evaluation of product performance parameters for a specified application under defined conditions and adequate quality assurance |
| VTC | Verification and Test Centre |



2. Introduction

Environmental technology verification (ETV) is an independent (third party) assessment of the performance of a technology or a product for a specified application, under defined conditions and quality assurance.

2.1. *Name of product*

The product is DANMIL DAVOC CAP.

2.2. *Name and contact of vendor*

DANMIL A/S
Greve Main 42
2670 Greve
Denmark
Phone + 45 7010 1030.
Contact: Michael Lindh
E-mail ml@danmil.dk

2.3. *Name of centre / verification responsible*

Test centre:
FORCE Technology
Park Allé 345
DK - 2605 Brøndby
Denmark.

Verification responsible
William Hansen
E-mail wha@force.dk
Phone +45 4326 7174
Cell phone +45 2218 1138

2.4. *Verification documentation*

The documentation of the verification process is described in four main documents in the order indicated below following the template of DANETV FORCE Technology verification centre quality manual /1/. The verification protocol and test plan result in a test and verification report, respectively. The verification report is the final completing document.

1. Verification Protocol
2. Test plan
3. Test Report
4. Verification Report

The verification process is summarized in the verification statement.

2.4.1. Verification document status

This Danmil Verification Report is a result of Danmil Verification Protocol /3/ and is referring to Danmil Test Report (Appendix 2).

2.5. Verification process

Verification and tests was conducted in two separate steps, as required by DANETV. The steps in the verification are shown in Figure 1.

Figure 1. Verification steps.

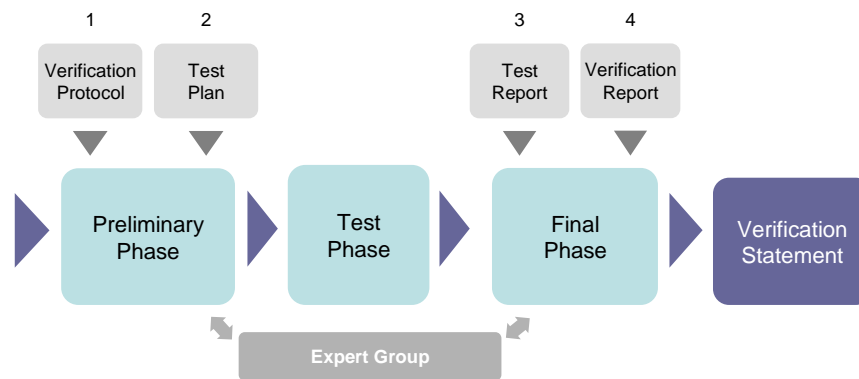

References for the verification process are the Quality Management Plan for DANETV /1/.

2.6. Verification and test organization

The verification was conducted by the Danish test centre DANETV. The verification is planned and conducted to satisfy the requirements of the ETV scheme currently being established by the European Union (EU ETV). Verification and tests was performed by FORCE Technology as DANETV verification and test centre (VTC).

The day to day operations of the verification and tests was coordinated and supervised by FORCE Technology. The testing was conducted at the FORCE Technology test site, Park Allé 345, DK- 2605 Brøndby, Denmark. FORCE Technology will operate the carbon filter during the verification. DANMIL A/S will provide the capsules.

A part of the verification organization is the expert group who supports FORCE Technology in planning, conducting and reporting the verification and tests. The expert group makes the review.

The organization chart in Figure 2 identifies the relationships of the organization associated with this verification and tests.

Figure 2. Organization of the verification and tests.

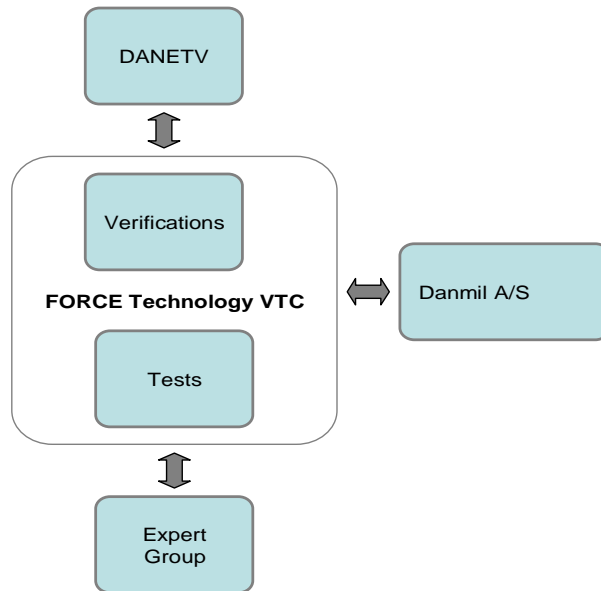

2.7. Expert group

The expert group assigned to this verification and responsible for review of the verification plan and report documents includes:

Ole Schleicher (OSC)
 Department for Air Pollution
 FORCE Technology
 Park Allé 345
 DK - 2605 Brøndby
 E-mail: osc@force.dk
 Phone +45 4326 7540

Qualification:

Ole Schleicher has more than 25 years of experience with air pollution abatement systems, including removal of VOC, Hg and PCDD/F from air and flue gasses with activated carbon. He has an in-depth knowledge of the theory and mechanism for the adsorption processes for activated carbon. He has also more than 10 years of experience in standardization as well as in testing the performance of many types of air purifying technologies.

3. Description of the technology

The technology to be verified is applying adsorption technology for removal of hydrocarbons in polluted air or gas stream.

Adsorption is a separation process based on solid components capability to remove gaseous components from a gas/air stream.

There are two types of adsorption: Either a physical or chemical (chemisorption).

Removal of hydrocarbons from polluted air is based upon physical adsorption technology. This adsorption method is often used as an efficient solution to reduce polluted components in a gas/air stream. By physical adsorption the polluted gaseous component (adsorbate) is adsorbed and maintained within and on the surface of the solid component (adsorbent).

The porosity and specific surface of the adsorbent and the concentration of the adsorbate have a major impact on the adsorption capacity.

4. Description of the product

The DANMIL A/S DAVOC CAP is a small carbon filter for removal of hydrocarbons in polluted air or gas stream e.g. CO₂ gas used for biological processes. The carbon filter consists of a polypropylene cylinder with easy-lock couplings in both ends for easy connection. Inside the cylinder is an activated carbon felt placed on a supporting mesh. A high efficient HEPA filter is placed at the outlet of the filter.

The filter is flow directional and marked with an arrow on the outside surface of the filter.

Generally the adsorption capability on activated carbon filters is depending on the following parameters:

- Type of carbon
- Type of organic compound or mixture of compounds to be adsorbed
- Air velocity through the activated carbon
- Filter design
- Temperature
- Humidity

The total adsorption capacity of the carbon implies the amount of adsorbed organic compound before the carbon is saturated.

Figure 3. Picture of a DAVOC CAP

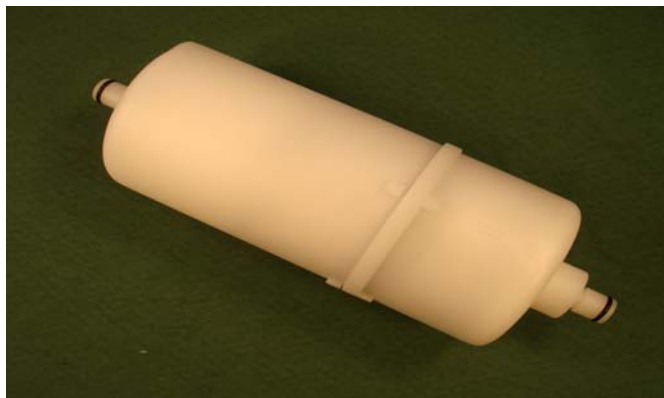

5. Application and performance parameter definitions

The application is defined as detailed in the application definition appendix, Appendix 1, in terms of matrix for use, targets and effects.

5.1. *Matrix*

The matrix of the application is air polluted with hydrocarbons.

For this verification toluene is selected as a representative for hydrocarbons.

The air has the following properties:

- Concentration of toluene approx. 50 ppm hydrocarbons
- Temperature below 25 °C
- Atmospheric pressure

5.2. *Target*

The target of the application is the total of hydrocarbons.

5.3. *Effects*

The effect of the application is removal of hydrocarbons.

The effect of the application is generally reported as the durability of the carbon filter under the given conditions (performance parameter).

5.4. *Performance parameters for verification*

The durability is determined by the time until breakthrough.

5.5. *Additional parameters*

The following parameters are additional parameters measured and reported for the period:

- Temperature
- Concentration of hydrocarbons

6. Existing data

No existing data are available.

7. Test plan requirements

Based upon the application and performance parameter identification, Section 5, the requirements for test design have been set, see below. The detailed test plan is prepared separately based upon the specification of test requirements presented below.

7.1. Test design

The principle for the test is: A constant flow of dried air polluted with a fixed concentration of toluene is led through the DAVOC CAP. The concentration of toluene is measured and logged continuously before and after the DAVOC CAP. Breakthrough is determined by an increase from below the detection limit to a measurable and increasing concentration of toluene after the filter. The test is repeated with three different concentrations of toluene.

7.2. Reference analysis

Not relevant, as no analysis is performed.

7.3. Data management

Data storage, transfer and control must be done in accordance with the requirements of ISO 9001 /2/ enabling full control and retrieval of documents and records.

7.4. Quality assurance

The quality assurance of the tests must include control of the test system and control of the data quality and integrity.

The test plan and the test report was subject to review by the expert group as part of the review of this verification protocol and the verification report, see Figure 2.

7.5. Test report

The test report must follow the template of DANETV FORCE Technology verification centre quality manual /1/ with data and records from the tests presented.

8. Evaluation

The evaluation includes calculation of the performance parameters, see Section 5.4.

Evaluation of the data quality is based upon the test quality assurance, see Section 7.4 for requirements.

8.1. Calculation of performance parameters

Calculations are done according to generally accepted mathematical and statistical principles such as those described in /2/ and as described in the Test Report (Appendix 2).

8.2. Performance parameter summary

Each test was carried out over a number of days with continuous operation around-the-clock. The operation was supervised twice a day by representatives from FORCE Technology in order to observe and secure that the operation conditions are inside the specified limits. The tests were stopped, when the gas monitor reading showed a clear breakthrough.

8.2.1. Test results

The overall results of the test, concerning the durability of the carbon filter is shown in table 1.

Table 1 Test results

| Test date (start) | Volume flow | Concentration (inlet) ¹ | Durability | |
|-------------------------|-------------|------------------------------------|------------|------|
| | l/min | ppm | minutes | days |
| 29-07-2009 | 3,3 | 432 | 670 | 0,5 |
| 31-07-2009 | 3,3 | 71 | 4.755 | 3,3 |
| 31-08-2009 ² | 3,3 | 17 | 8.485 | 5,9 |

¹ Average values

² The result has been corrected from 4.4 l/minute to 3.3 l/minute (see section 7.3)

The durability as a function of inlet concentration is shown in figure 4.

Figure 4 Durability in days versus average inlet concentration

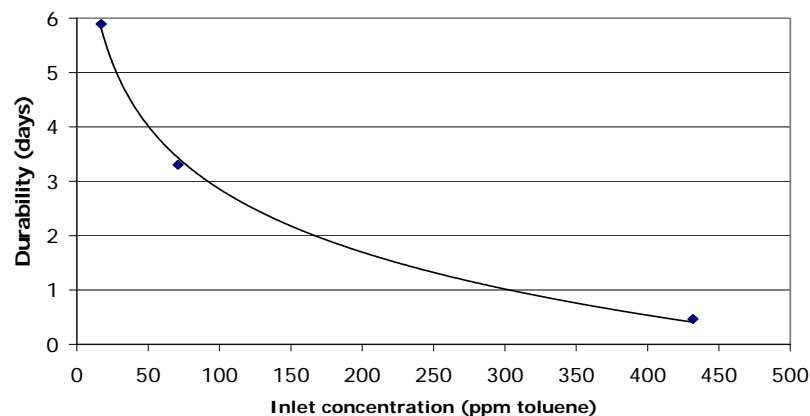

The curve shows that the durability increases with lower concentration.



8.3. Evaluation of test quality

All measuring, handling of data and calculation of results have been carried out according to the FORCE Technology DANAK accreditation No. 51 (also for parameters not covered by the accreditation).

The evaluation of the test and the results has proven that the quality and the accuracy fulfil the requirements stated in the DANAK accreditation No. 51 /2/.

8.4. Control of data quality

Transfer of data from handwritten form to computer, has been subjected to 100 % control by a second person.

The operational data verifies that the test has been in agreement with the determined conditions in the test plan /4/ is shown in Appendix 2 (Test Report).

8.5. Deviations

It was not possible to maintain a constant inlet concentration of toluene. The concentration decreased during the tests, but it is considered to have insignificant influence on the results.

In test 3 the flow was 4.4 l/minute while it was 3.3 l/minute in the two first tests. The durability for test 3 has been corrected inversely proportionally from 4.4 to 3.3 l/minute.

This results in a minor underestimation of the durability, because the adsorption is more effective at a lower flow.

8.6. Additional parameter summary

The test was conducted at room temperature.

The concentration of toluene in the air before and after the DAVOC CAP was measured and recorded continuously. As to the inlet concentration it was not possible to maintain a constant concentration.

8.7. Product costs

No exact information on the investment and operational cost has been available for the filter.

8.8. Occupational health and environment

It is confirmed that the use of the product does not imply special health, safety and waste issues during the test.



The work during testing was carried out according to the FORCE Technology Safety Rules, which complies with the extensive Danish rules for safe occupational health and the European regulations of work with chemicals.

8.9. Recommendations for verification statement

The verification of the adsorption technology is completed as described in section 2.4.

On the basis of the verification process, relevant documents and the evaluation (see section 8) it is recommendable to issue a verification statement to the vendor.

| | | | |
|--|---------|----------------------------|-----------|
| Signed by | 29/6-10 | Signed by | 29/6 - 10 |
| Annemette Geertinger | Date | William Hansen | Date |
| Deputy Manager | | Verification Responsible | |
| DANETV Steering Committee member | | DANETV Verification Centre | |
| FORCE Technology - Air Emission and Energy Efficient Technology Verification Centre | | | |



9. References

1. DANETV at FORCE Technology. Verification Test Centre Quality Manual. February 2009.
2. DANAK accreditation number 51
3. Verification Protocol, Danmil DAVOC CAP, June 2009
4. Test Plan, Danmil DAVOC CAP, June 2009

10. Appendix

- Appendix 1 Application and performance parameter definitions
- Appendix 2 Test Report, Danmil DAVOC CAP, June 2010
- Appendix 3 Review Report

Appendix 1

Application and performance parameter definitions



This appendix defines the application and the relevant performance parameters application as input for verification and test of an environmental technology following the DANETV method.

1. *Application*

The intended application of the product for verification is defined in terms of the matrix, the targets and the effects of the product.

1.1. **Matrix**

The matrix of the application is air polluted with hydrocarbons, and the field of application is an investigation on the adsorption of one or more hydrocarbons on a carbon filter. For this verification toluene is selected as a representative for hydrocarbons.

The applied air has the following properties:

- Concentration of toluene approx. 50 ppm
- Temperature below 25 °C
- Atmospheric pressure

1.2. **Target**

The target of the application is hydrocarbons.

1.3. **Effects**

The effect of the application is removal of hydrocarbons.

The effect for the application is generally reported as the durability (until breakthrough) of the carbon filter measured in time under the given conditions (performance parameter).

2. *General performance requirements*

No formal performance requirements for the application have been identified in the European Union or the US.

3. *State of the art performance*

Not relevant

4. *Performance parameter definitions*

The durability is determined by the concentration of hydrocarbon in the air, the amount of air and the capacity to adsorb hydrocarbons.

During operation, the following operation conditions are recorded:

- temperature
- concentration

Appendix 2

Test Report



DANMIL DAVOC CAP

Test Report

Removal of hydrocarbons from polluted air



0. Table of contents

| | |
|--|-----------|
| 0. TABLE OF CONTENTS | 2 |
| 1. ABBREVIATION AND DEFINITIONS | 3 |
| 2. INTRODUCTION | 4 |
| 2.1. VERIFICATION DOCUMENT STATUS | 4 |
| 2.2. VERIFICATION PROTOCOL REFERENCE | 4 |
| 2.3. NAME AND CONTACT OF VENDOR | 4 |
| 2.4. NAME OF CENTRE/TEST RESPONSIBLE | 4 |
| 2.5. EXPERT GROUP | 4 |
| 3. TEST DESIGN | 5 |
| 3.1. TEST SITE | 6 |
| 3.2. TESTS | 6 |
| 3.2.1. TEST METHODS | 6 |
| 3.2.2. TEST STAFF | 7 |
| 3.2.3. TEST SCHEDULE..... | 7 |
| 3.2.4. TEST EQUIPMENT | 8 |
| 3.2.5. OPERATION CONDITIONS | 9 |
| 3.2.6. OPERATION MEASUREMENTS | 9 |
| 3.2.7. PRODUCT MAINTENANCE | 9 |
| 3.2.8. HEALTH, SAFETY AND WASTES | 9 |
| 4. REFERENCE ANALYSIS | 9 |
| 5. DATA MANAGEMENT | 10 |
| 5.1. DATA STORAGE, TRANSFER AND CONTROL | 10 |
| 6. QUALITY ASSURANCE | 10 |
| 6.1. TEST REPORT REVIEW | 10 |
| 6.2. PERFORMANCE CONTROL – REFERENCE ANALYSIS..... | 10 |
| 6.3. DATA INTEGRITY CHECK PROCEDURES | 10 |
| 7. TEST RESULTS | 11 |
| 7.1. TEST SUMMARY..... | 11 |
| 7.2. TEST RESULTS | 11 |
| 7.3. DEVIATIONS FROM TEST PLAN | 12 |
| 8. REFERENCES | 13 |



1. Abbreviation and definitions

The abbreviations and definitions used in the verification protocol and the test plan are summarized below.

| Word | DANETV |
|------------------------|--|
| Effect | The way the target is affected |
| ETV | Environmental technology verification (ETV) is an independent (third party) assessment of the performance of a technology or a product for a specified application, under defined conditions and adequate quality assurance. |
| Evaluation | Evaluation of test data for a technology product for performance and data quality |
| Matrix | The type of material that the product is intended for |
| Method | Generic document that provides rules, guidelines or characteristics for tests or analysis |
| Performance claim | The effects foreseen by the vendor on the target(s) in the matrix of intended use |
| Performance parameters | Parameters that can be documented quantitatively in tests and that provide the relevant information on the performance |
| QA | Quality assurance |
| Standard | Generic document established by consensus and approved by a recognized standardization body that provides rules, guidelines or characteristics for tests or analysis |
| Target | The property that is affected by the product |
| Test/testing | Determination of the performance of a product for parameters defined for the application |
| Verification | Evaluation of product performance parameters for a specified application under defined conditions and adequate quality assurance |
| VTC | Verification and Test Centre |



2. Introduction

2.1. Verification document status

This test report is the implementation of a test design developed for verification of the performance of an environmental technology following the DANETV method. See the verification protocol /1/ for details on organization and implications.

2.2. Verification protocol reference

DANMIL DAVOC CAP, Verification Protocol, June 2009.

2.3. Name and contact of vendor

DANMIL A/S
Greve Main 42
2670 Greve
Denmark
Phone + 45 7010 1030
Contact: Michael Lindh
E-mail ml@danmil.dk

2.4. Name of centre/test responsible

Test centre:
FORCE Technology
Park Allé 345
DK - 2605 Brøndby
Denmark.

Test_responsible:
Ole Tvede Larsen
E-mail otl@force.dk
Phone +45 4326 7168
Cell phone +45 4082 9873

2.5. Expert group

The expert group assigned to this verification and responsible for review of the verification plan and report documents includes:

| | |
|--|---|
| <p>Ole Schleicher (OSC) Department for Air Pollution FORCE Technology Park Allé 345 DK - 2605 Brøndby E-mail: osc@force.dk Phone +45 4326 7540</p> | <p>Qualification: Ole Schleicher has more than 25 years of experience with air pollution abatement systems, including removal of VOC, Hg and PCDD/F from air and flue gasses with activated carbon. He has an in-depth knowledge of the theory and mechanism for the adsorption processes for activated carbon. He has also more than 10 years of experience in standardization as well as in testing the performance of many types of air purifying technologies.</p> |
|--|---|

3. Test design

The principle for the test is: A constant flow of dried air polluted with a fixed concentration of toluene is led through the DAVOC CAP. The concentration of toluene is measured and logged continuously before and after the DAVOC CAP. Breakthrough is determined by an increase from below the detection limit to a measurable and increasing concentration of toluene after the filter (see figure 1). The test is repeated with three different concentrations of toluene.

Figure 1. Illustration of breakthrough

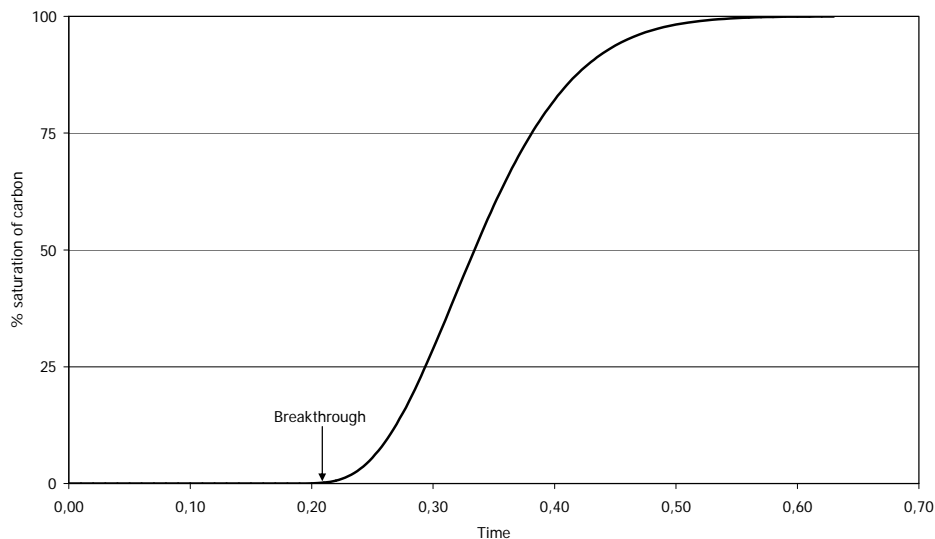

The test is done in an air conditioned room, with a constant temperature of $20\text{ }^{\circ}\text{C} \pm 2\text{ }^{\circ}\text{C}$, to avoid temperature impact on the evaporation rate of toluene and the adsorption conditions in the DAVOC CAP.

The air flow is 3 - 4 l/min.

The test gas is atmospheric air, which is dried by means of a silicagel filter to avoid impact on the filter capacity from adsorption of water. The dry air is blown over a liquid surface of the toluene in a small bottle, from where a constant rate of toluene is aimed to evaporate. Before entering the carbon filter, the contaminated air is diluted with dry air to achieve the test flow and concentration.

The concentration of the contaminated air before the DAVOC CAP is measured and logged continuously by means of a gas monitor in order to evaluate how constant the concentration is through the test. The total amount of toluene in air is determined by weighing the bottle before and after the test.

The concentration of the contaminated air after the DAVOC CAP is measured and logged continuously by means of a gas monitor to register the breakthrough, which is



defined as the time, where the concentration after the DAVOC CAP is increased to 0.1% of the concentration before.

The three test concentration levels are selected both higher and lower than 50 ppm in order to cover a suitable range.

The adsorption capacity for the activated carbon is also affected by the atmospheric pressure, but the effect from the day to day variations in the atmospheric pressure is considered to be insignificant, and will not be taken into account in the verification. If the DAVOC CAP is used in areas with substantially lower atmospheric pressure, the capacity will be lower.

3.1. Test site

The test was conducted in the test site at:

FORCE Technology
Park Allé 345
2605 Brøndby
Denmark.

3.2. Tests

DANMIL DAVOC CAP - carbon filter is tested for its adsorption capacity in accelerated tests, i.e. in concentration ranges higher than the range of the matrix for the application. From the test results the durability (until breakthrough) of the carbon filter is estimated for the range of the matrix.

During the test it is expected to observe the effect of various concentrations of toluene.

3.2.1. Test methods

The test methods are shown in the following table 1.

Table 1. Test method

| Performance parameter | Scope of measurements | Measurements methods and readings ¹ |
|-----------------------|---|---|
| Durability | Room temperature | Air condition equipment according to internal procedure for calibration laboratory. Temperature interval: 20°C – 22°C |
| | Concentration of hydrocarbons before filter | Continuous measurement in accordance with DANAK accreditation no. 51 /2/ Gas monitor inlet (see section 3.2.4) Calibrated with toluene Uncertainty: ±10% |
| | Concentration of hydrocarbons after filter | Continuous measurement Gas monitor outlet (see section 3.2.4) Internal calibration factor for toluene Uncertainty: ±10% Detection limit: 2 ppb (7,6 µg/m ³) |
| | Weight of toluene | Weighing of toluene evaporated (as difference before and after test) Laboratory scale Calibrated according to DANAK accreditation no. 51 /2/ Uncertainty: ±3 mg Detection limit: 3 mg |
| | Volume treated | Gas meter reading on calibrated pump Uncertainty: ±5% Calibration according to DANAK accreditation no. 51 /2/ |
| | Time | Manual registration of time elapsed |

¹ Uncertainty is given as 95 % confidence interval

3.2.2. Test staff

Test staff is: Arne Oxbøl
Test responsible: Ole Tvede Larsen

3.2.3. Test schedule

The test schedule is showed in the following Table 2:

Table 2. Test schedule

| Task | 26 | 27 | 28 | 29 | 30 | 31 | 36 | 37 | 38 | 39 | 40 |
|---------------------------------|----|----|----|----|----|----|----|----|----|----|----|
| Test plan | x | x | | | | | | | | | |
| Mounting test set up | | | x | x | | | | | | | |
| Test functioning of test set up | | | | x | | | | | | | |
| Primary test | | | | | x | | | | | | |
| Test periode | | | | | | x | x | | | | |
| Data handling and calculation | | | | | | | | x | | | |
| Draft Test Report and QA | | | | | | | | | x | x | |
| Final Test Report | | | | | | | | | | x | x |

3.2.4. Test equipment

The test set up is schematically shown in the following figure 2.

Figure 2 The test set up for testing Danmil DAVOC CAP

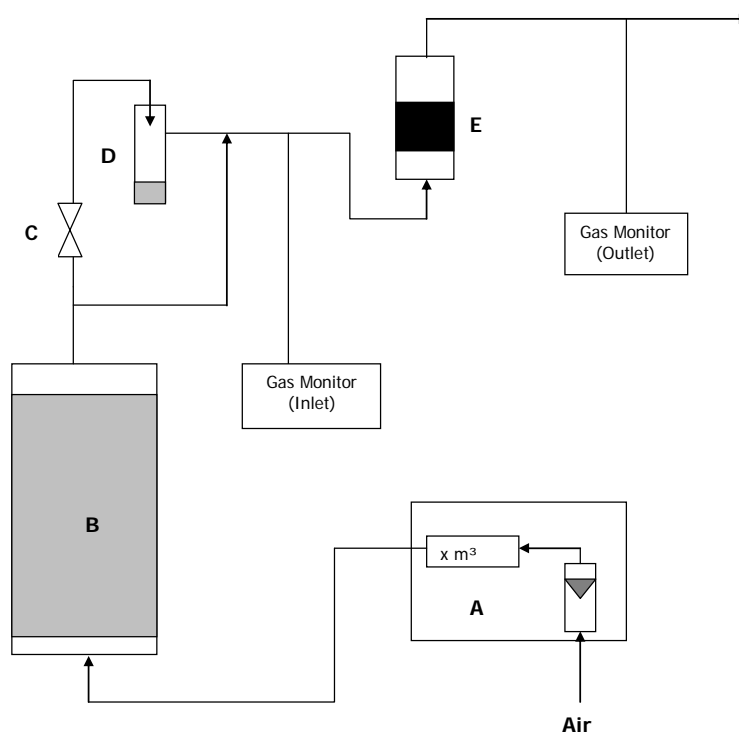

- A Pump with flowmeter and gasmeter
- B Air drying unit with silicagel
- C Needle valve
- D Bottle with toluene
- E DAVOC CAP

Gas Monitor inlet: Photo Acoustic Infrared Spectroscopy (Brüel & Kjær Gas Monitor 1302)
 Gas Monitor outlet: Photo Ionization Detector (ppBRAE)



3.2.5. Operation conditions

The operation conditions applied during the verification of the product are:

1. Constant temperature in the test-room ($20\text{ °C} \pm 2\text{ °C}$)
2. Dry air to avoid adsorption of water on the carbon.
3. Constant air flow
4. Toluene concentration
5. Toluene concentration before and after the DAVOC CAP
6. The flow is 3-5 l/min. With 3 months of operation the consumption of CO_2 is $390 - 650\text{ m}^3$. It is assumed that this volume is costly, thus the test was performed with atmospheric air instead.

3.2.6. Operation measurements

During operation, the following operation parameters are manually recorded by inspection of the test equipment twice a day:

- Time
- Room temperature
- Air flow by flow meter
- Total air volume by gas meter.

Toluene used is determined by weighing the bottle at test start and test stop.

The concentration of toluene in the air before and after the DAVOC CAP is measured and recorded continuously.

3.2.7. Product maintenance

Not relevant. The capsule is discarded after use.

3.2.8. Health, safety and wastes

The use of the product does not imply any special health, safety and waste issues. Used solvents and DAVOC CAPs was disposed regarding to laboratory practise.

The work during testing was done according to the FORCE Safety Rules that are compliant with the extensive Danish rules for safe occupational health and the European regulations of work with chemicals.

4. Reference analysis

Not relevant, as no analysis is performed.



5. Data management

Handling of data and calculation of results is performed according to the FORCE Technology DANAK accreditation no. 51 (also for parameters not covered by the accreditation).

Calculations was performed by approved spread sheets and controlled spread sheet calculations.

5.1. *Data storage, transfer and control*

All reading data was stored in handwritten form on paper and schemes.

All the data stored in data loggers was transferred to the FORCE computer system, which is regularly backed up for data safety.

6. Quality assurance

All measuring, handling of data and calculation of results is performed according to the FORCE Technology DANAK accreditation no. 51 (also for parameters not covered by the accreditation).

6.1. *Test report review*

The test plan was subject to internal review by the verification responsible from FORCE Technology VTC Verifications:

William Hansen
E-mail: wha@force.dk
Phone +45 4326 7174
Cell phone: +45 2218 1138

External review of the test report is done by the expert group assigned to this verification /see paragraph 2.4). The review of the verification report will include the full test report as an Appendix.

6.2. *Performance control – reference analysis*

Not relevant, as no analysis is performed.

6.3. *Data integrity check procedures*

All transfer of data from handwritten form to computer, was subjected to 100 % control by another person.



Approved spread sheets for calculations of results has been subjected to an intensive control, to assure correct calculations, and consequently no further control is necessary.

New calculations in spread sheets was subjected to 100 % check of all formulas and spot check of at least 20 % of all copies of the formulas.

7. Test results

7.1. Test summary

The test was conducted at FORCE Technology test site, Park Allé 345, DK 2605 Brøndby, on behalf of Danmil A/S and coordinated by FORCE Technology.

The DANMIL A/S DAVOC CAP was tested for its ability to remove hydrocarbons from polluted air (measured in time until breakthrough).

During operation, the operation conditions were recorded as mentioned in section 3.2.1. to 3.2.7.

Each test was carried out over a number of days with continuous operation around-the-clock. The operation was supervised twice a day by representatives from FORCE Technology in order to observe and secure that the operation conditions are inside the specified limits. The tests were stopped, when the gas monitor reading showed a clear breakthrough.

7.2. Test Results

The overall results of the test, concerning the durability of the carbon filter is shown in Table 3.

Table 3 Test results

| Test date (start) | Volume flow | Concentration (inlet) ¹ | Durability | |
|-------------------------|-------------|------------------------------------|------------|------|
| | l/min | ppm | minutes | days |
| 29-07-2009 | 3,3 | 432 | 670 | 0,5 |
| 31-07-2009 | 3,3 | 71 | 4.755 | 3,3 |
| 31-08-2009 ² | 3,3 | 17 | 8.485 | 5,9 |

¹ Average values

² The result has been corrected from 4.4 l/minute to 3.3 l/minute (see section 7.3)

The durability as a function of inlet concentration is shown in figure 3.

Figure 3 Durability in days versus average inlet concentration

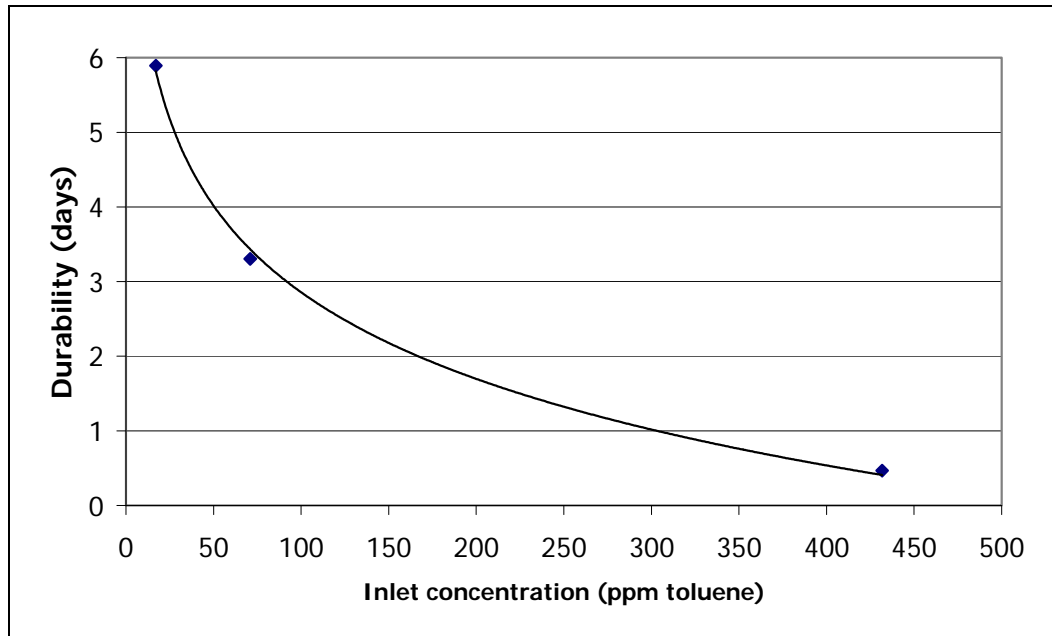

The curve shows that the durability increases with lower concentration.

7.3. Deviations from test plan

It was not possible to maintain a constant inlet concentration of toluene. The concentration decreased during the tests, but it is considered to have insignificant influence on the results.

In test 3 the flow was 4.4 l/minute while it was 3.3 l/minute in the two first tests. The durability for test 3 has been corrected inversely proportionally from 4.4 to 3.3 l/minute.

This results in a minor underestimation of the durability, because the adsorption is more effective at a lower flow.

| | | | |
|--|---------|----------------------------|-----------|
| Signed by | 29/6-10 | Signed by | 29/6 - 10 |
| Annemette Geertinger | Date | Ole Tvede Larsen | Date |
| Deputy Manager | | Test Responsible | |
| DANETV Steering Committee member | | DANETV Verification Centre | |
| FORCE Technology - Air Emission and Energy Efficient Technology Verification Centre | | | |



8. References

1. DANMIL DAVOC CAP, Verification Protocol, June 2009.
2. DANAK Accreditation number 51
3. DANETV at FORCE Technology. Verification Test Centre Quality Manual. 27-2-2009.

Appendix 3

Review Report



Comments, questions and proposals for improvements of the test plan and test report documents have been communicated from internal reviewer and stored according to the archiving procedures described in the FORCE Technology Centre Quality Manual.